

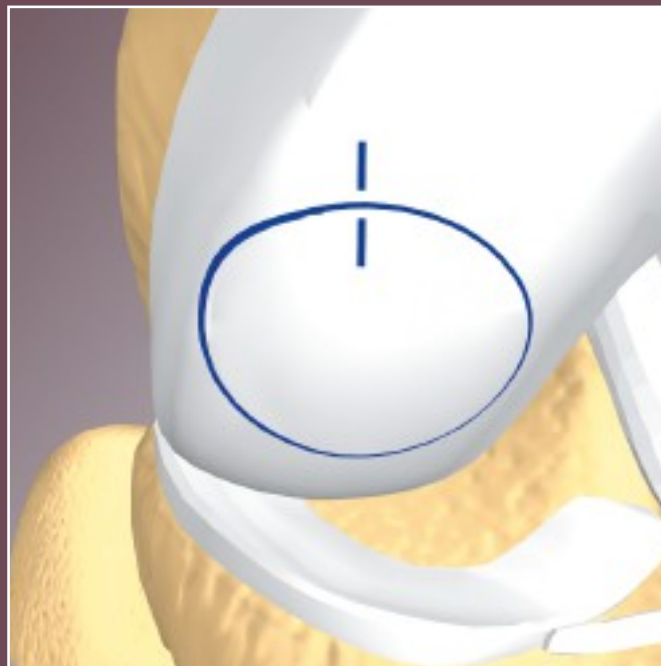

Allograft OATS® (Osteochondral Autograft Transfer System)

Surgical Technique



Allograft OATS® (Osteochondral Autograft Transfer System)



Following standard preoperative examination and diagnostic studies confirming the size and extent of the lesion, a standard para-patellar arthrotomy is carried out to expose the defect. Cannulated Allograft OATS Sizers in various sizes are selected to estimate and approximate coverage of the lesion.

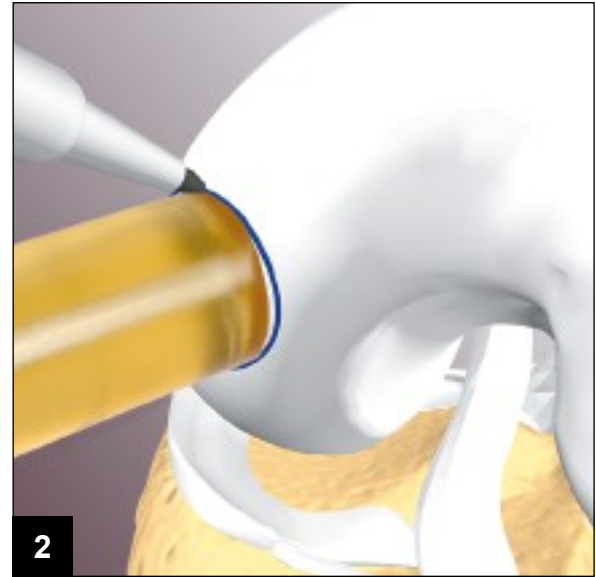

Once the appropriate size is determined, a circumferential mark is made on the condyle around the cylinder (*be sure the sizer is perpendicular to the condyle surface*). A Drill Tip Guide Pin is drilled through the sizer into bone. The sizer is removed and a reference mark is placed in a superior 12:00 position.

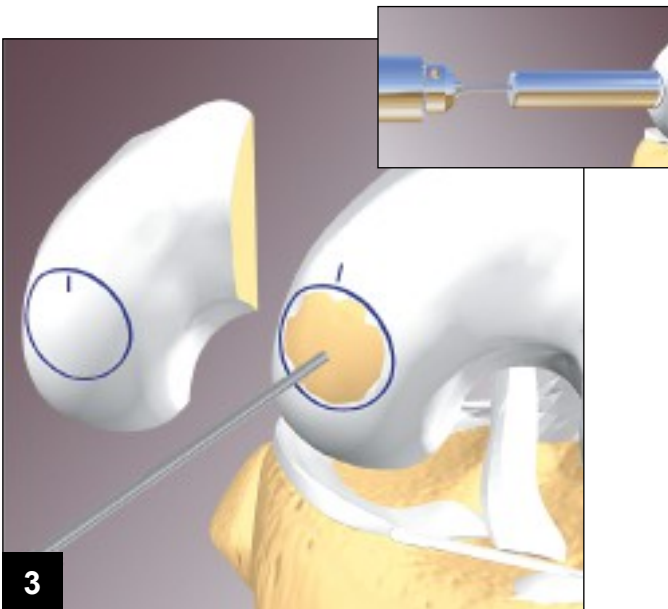

The sizer previously used to establish the recipient defect size is placed over the allograft hemi-condyle and circumferentially marked. The sizer is removed and a reference mark is placed in a superior 12:00 position on the inside of the circle mark on the graft.

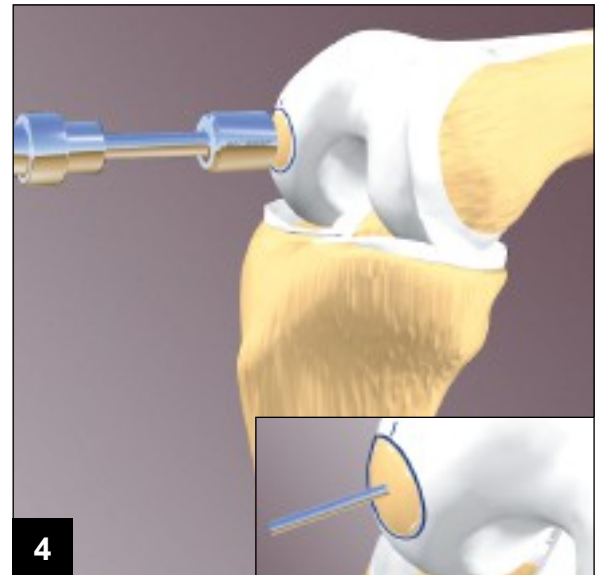

The sizer is replaced with an appropriately sized Recipient Harvester. The peripheral cartilage is scored to the underlying subchondral bone. The harvester is then removed leaving the Drill Tip Guide Pin in place.

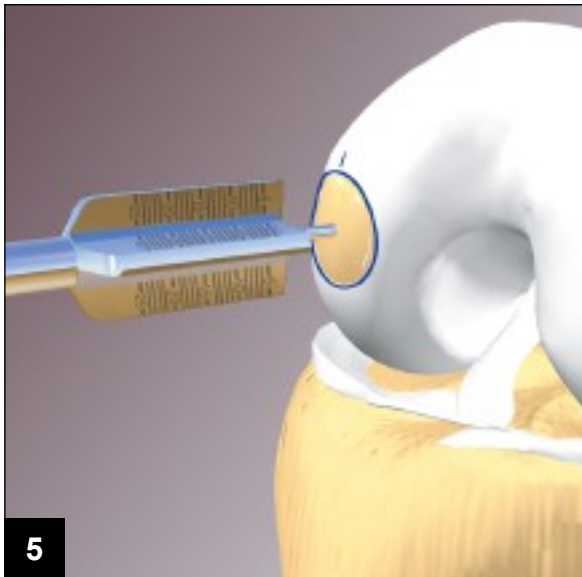

The graduated Allograft OATS Recipient Counterbore is then secured to the drill and placed over the drill pin. The counterbore is then drilled into the defect and subchondral bone to a depth of 6 to 8 mm. Bleeding subchondral surfaces should be confirmed.

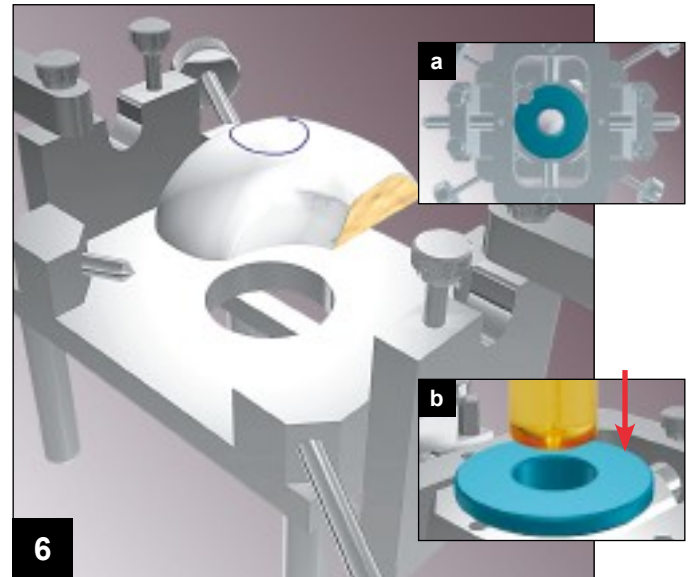

The donor condyle is secured in the Allograft OATS Workstation. The Allograft OATS Workstation Bushing of corresponding size is placed into the top housing over the graft (a) and set to the exact angle using the large end of the cannulated sizer (b) necessary to match the recipient's contour. The housing is securely fastened.

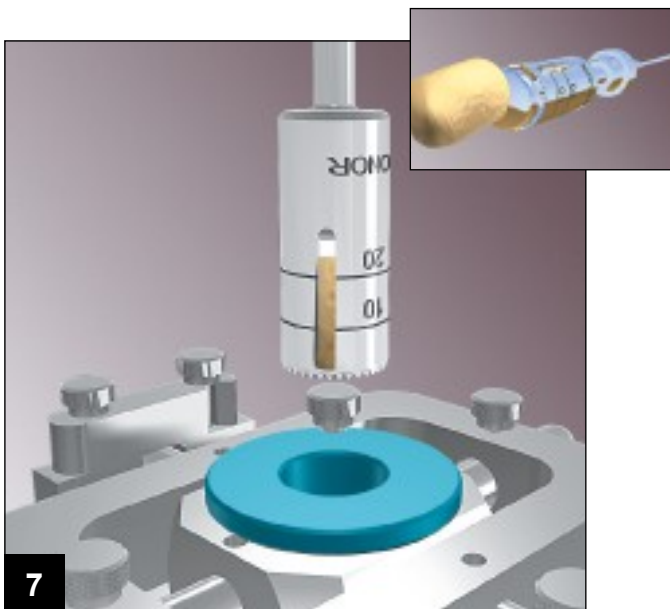

The Allograft OATS Donor Harvester with a collared guide pin is then connected to a drill and passed into the proximal graft housing and rested upon the graft's surface. The harvester is subsequently drilled through the entirety of the allograft donor. Remove the harvester and gently extract the graft.

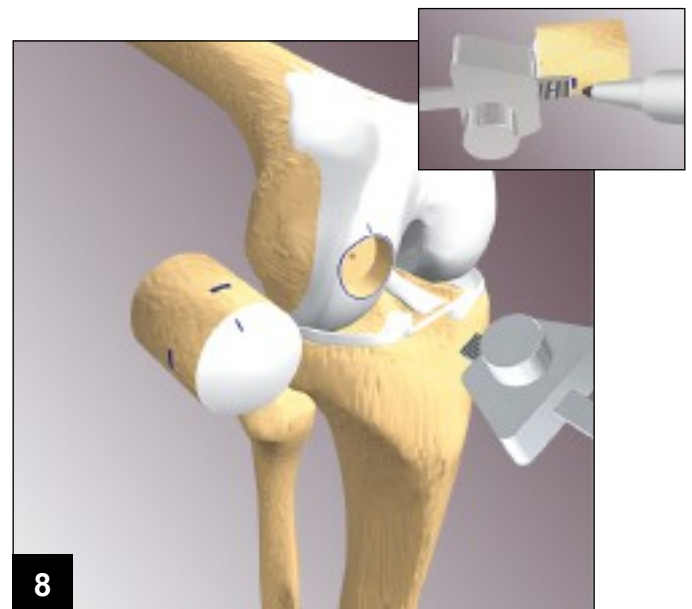

The depth measurement guide is used to measure the recipient depth in four quadrants: north, south, east and west. The graft is appropriately measured and marked by referencing the four quadrant depths recorded from the recipient socket that was created.

Workstation Assembly Instructions

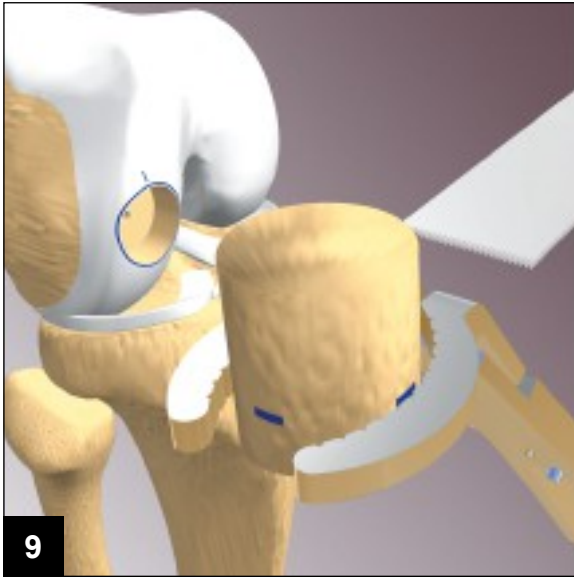

9
The allograft is secured in the Allograft OATS Holding Forceps and trimmed by a saw to achieve the appropriate press fit accommodation of the recipient socket depth. The allograft should be positioned with the articular surface inferior to cut.

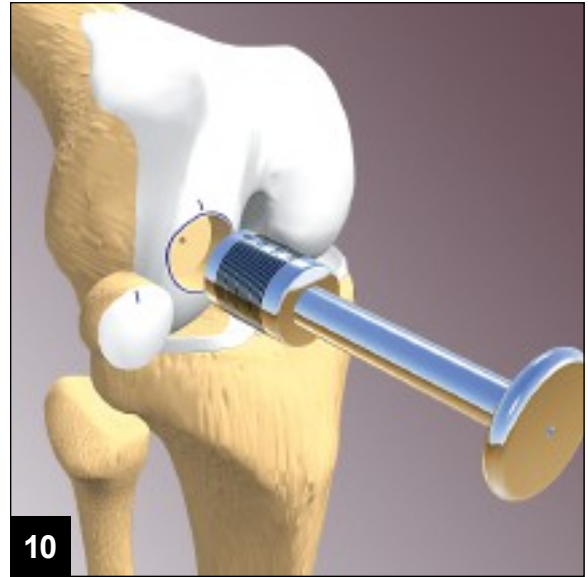

10
A graduated Allograft OATS Dilator is inserted into the recipient's socket site to achieve a one half mm socket dilation. Lightly tap the end of the dilator with a mallet. Dilation will also smooth the recipient socket's surfaces.

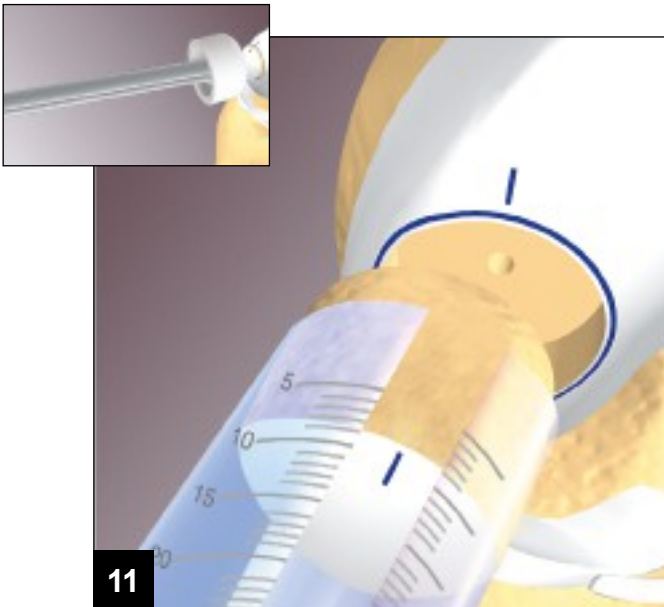

11
Once the precise depth of the graft (*matching recipient socket*) is obtained, the graft is placed in the appropriate clear Allograft Delivery Tube. Using a sizer one size smaller than the Delivery Tube as a plunger, the graft is line-fitted with reference to the appropriate mark into the recipient bed. A tamp corresponding to the graft's size, with appropriate tamp cover in place, is positioned against the allograft. Gentle taps are recommended for final seating.

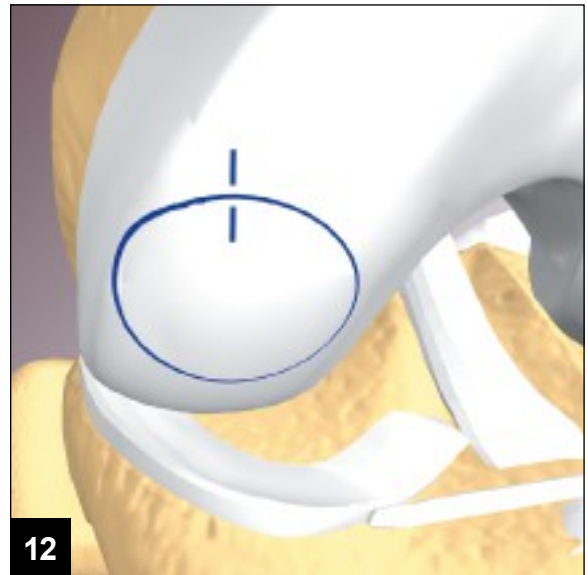

12
The graft is implanted until all edges are flush with the surrounding cartilage rim. In situations necessary for graft removal, an Allograft OATS Graft Retriever may be secured into the allograft to facilitate extraction.

Workstation Assembly Instructions

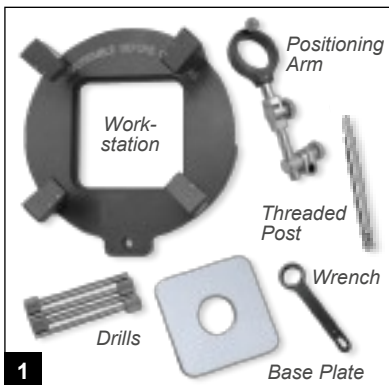

1 Remove the workstation, drill sleeves, positioning arm, threaded post, wrench and base plate from the instrumentation case.

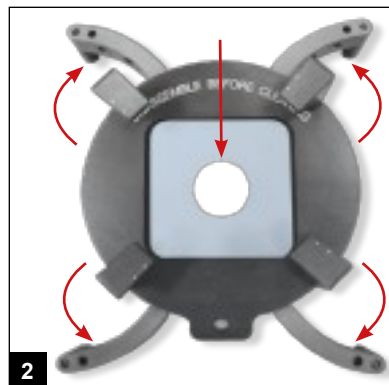

2 Rotate all four legs out until locked into position. Place the base plate insert into workstation pocket with the grooved side up.

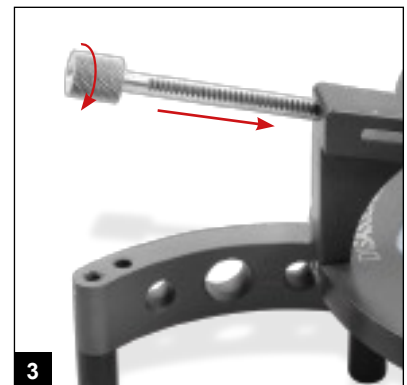

3 Insert four drill sleeves into the drill sleeve brackets on the workstation. Rotate the ratchet teeth on the drill sleeve to align with the ratcheting mechanism in the bracket.

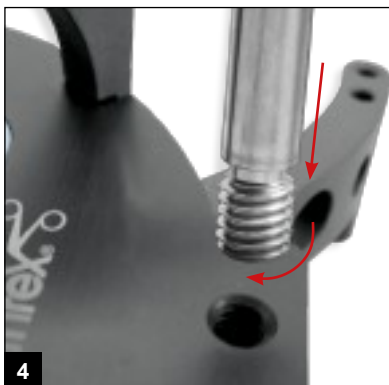

4 Thread the threaded post into the workstation using the wrench at the top of the post, and secure tightly.



5 Remove the positioning arm attachment from the case.



6 Insert positioning arm into the threaded post and temporarily secure by tightening both knobs on the positioning arm and the post. Ensure that the bushing knob is oriented up.

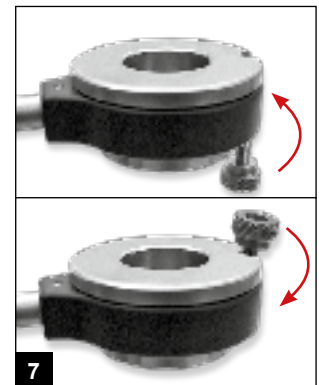

7 Insert specific allograft bushing into the arm attachment. Secure bushing with attached set screw.

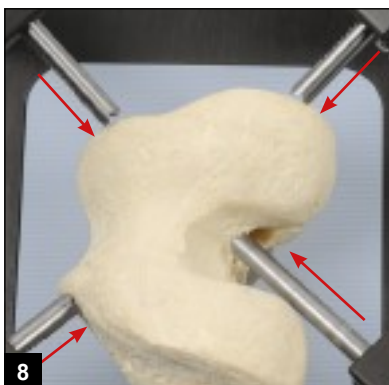

8 Place the allograft onto the workstation base and secure with the ratcheting drill sleeves by advancing sleeves snugly into the allograft. 2.4 mm K-wires may be used to augment this fixation.

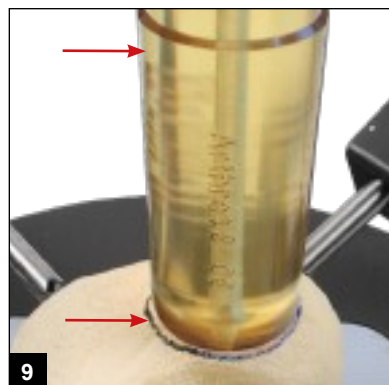

9 Do not insert K-wires so far that they are cut when harvesting the donor core. Mark the donor core with the LARGE end of the allograft sizer.

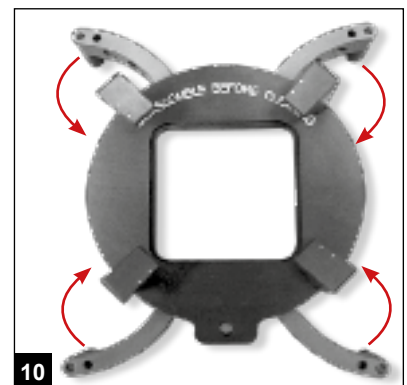

10 Leave the workstation legs extended. Clean all the individual disassembled parts. Close all four legs by slightly pulling downward to unlock before rotating closed. All cleaned parts are now ready to be placed in designated areas within the instrument case.

Ordering Information

Allograft OATS Set (AR-4075S) includes:

Drill Tip Guide Pin, 2.4 mm, qty. 2	AR-1250LS
Hudson Adapter	AR-1416
Quick Connect T-Handle	AR-1416T
Graft Retriever, 10 mm	AR-1988-10
Allograft OATS Tunnel Measurement Guide	AR-4071
Allograft Delivery Tubes, 15 mm - 35 mm	AR-4073-15 - 35
Allograft OATS Holding Forceps	AR-4076
Allograft OATS Recipient Harvesters, 15 mm - 35 mm	AR-4077-15 - 35
Allograft OATS Donor Harvesters, 15 mm - 35 mm	AR-4078-15 - 35
Allograft OATS Recipient Counterbores, 15 mm - 35 mm	AR-4079-15 - 35
Allograft OATS Sizers, 15 mm - 35 mm	AR-4080-15 - 35
Allograft OATS Workstation Bushings, 15 mm - 35 mm	AR-4081-15 - 35
Allograft OATS Collared Pins, 15 mm - 35 mm	AR-4082-15 - 35
Trochlear Groove Allograft Sizer/Tamps, 15 mm - 35 mm	AR-4083-15 - 35
Allograft OATS Depth Measurement Guide	AR-4085
SS Hex	AR-4086
Allograft OATS Workstation	AR-4087W
Allograft OATS Dilators, 15 mm - 35 mm	AR-4088-15- 35
Allograft OATS Tamp, small	AR-4091-S
Allograft OATS Tamp, medium	AR-4091-M
Allograft OATS Tamp, large	AR-4091-L
Allograft OATS Instrumentation Cases	AR-4096 - 4099
Allograft OATS Shipping Case	AR-4094

Accessories:

Allograft OATS Tamp Cover, small	AR-4091C-S
Allograft OATS Tamp Cover, medium	AR-4091C-M
Allograft OATS Tamp Cover, large	AR-4091C-L



www.arthrex.com

This description of technique is provided as an educational tool and clinical aid to assist properly licensed medical professionals in the usage of specific Arthrex products. As part of this professional usage, the medical professional must use their professional judgment in making any final determinations in product usage and technique. In doing so, the medical professional should rely on their own training and experience and should conduct a thorough review of pertinent medical literature and the product's Directions For Use.

Designed in conjunction with John C. Garrett, M.D., Atlanta, GA
U.S. PATENT NO. 5,919,196 and PATENT PENDING
© Arthrex GmbH, 2014. All rights reserved. LT2-0175-EN_A